



SL 50 STRIP LINE 50 Ω



SL 50

- **EMC tests for vehicle components immunity to RF fields**
- **Conform with ISO 11452-5**
- **Efficient power conversion provides high fields with minimum power**

The transversal electromagnetic mode which can developed in the SL 50 strip line, provides the opportunity for doing EMC testing inside the strip line. The geometrical dimensions having a line impedance of $Z = 50 \Omega$. At the end is required a 50Ω termination.

Typical for this strip line is the low power request for high field strength values. The strip line is specified in ISO 11452-5 'Road Vehicles electrical disturbances through radiated narrow-band electromagnetic energy: Measurement procedure for components part 5: Strip Line'. The SL 50 allows testing electrical/electronic sub modules (EUB) and their associated cables.

The SL 50 consists of two parallel metal plates. The EUT is arranged in the middle between these plates. The largest outer dimension of the EUT should not be more than 1/3 of the plate distance. The ground is on the lower plate and the isolated upper plate is supplied with RF energy. Between the plates, an electromagnetic field will be established. A typical test configuration consists of signal generator, power amplifiers, power meters and SL 50. To avoid interactions with the environment, the test should be run in an anechoic test chamber.

Technical specifications

Frequency range:	10 kHz to 1000 MHz
Max. input power:	1000 W
Connector type:	N, 50 Ω female
Typical impedance:	50 Ω
Typical VSWR (30 - 1000 MHz):	1: 1.3
Typical CW Input power for 10 V/m:	0.1 W (20 dBm)
Net power for 10 V/m as calculated according ISO 11452-5:	0.045 W (16.5 dBm)
Distance between the plates:	150 mm
Dimensions (without options):	4.3 m x 1.5 m x 0.17 m
Environment:	Indoor



SL 50 detail view

Model No. and options

Part number	Description
234751	SL 50 Strip Line ISO 11452-5, typical impedance 50 Ohms
234790	SL 50-s Strip Line ISO 11452-5, typical impedance 50 Ohms, with hinged desktop, moveable and for a door wide of 1.20 m



Advanced Test Solutions for EMC



SL 50 STRIP LINE 50 Ω

Example of a typical set-up

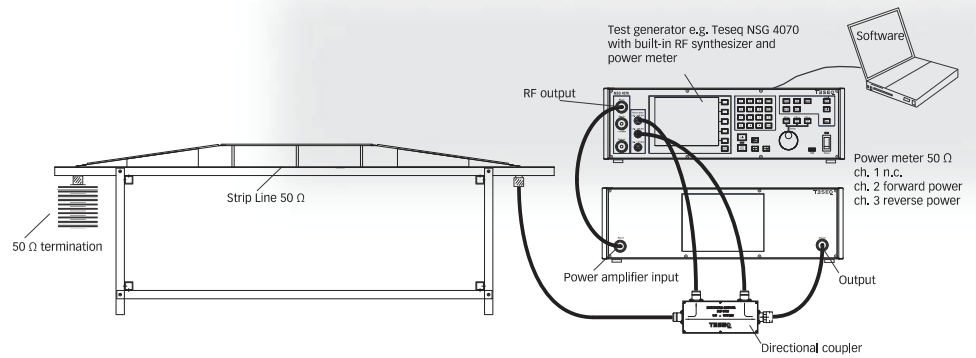

SL 50-s, version with hinged desktop,
view 1



SL 50-s, view 2



SL 50-s, view 3

取扱代理店



本 社	TEL : 06-6353-5551	兵庫営業所	TEL : 0798-66-2212
京都営業所	TEL : 075-671-0141	姫路営業所	TEL : 079-271-4488
滋賀営業所	TEL : 077-566-6040	姫路中央営業所	TEL : 079-284-1005
奈良営業所	TEL : 0742-33-6040	川崎営業所	TEL : 044-222-1212

メールでのお問い合わせ : webinfo@kokka-e.co.jp

Teseq GmbH
Landsberger Str. 255 12623 Berlin Germany
T +49 30 56 59 88 35 F +49 30 56 59 88 34
desales@teseq.com www.teseq.com

Teseq® is an ISO-registered company. Its products are designed and manufactured under the strict quality and environmental requirements of ISO 9001.

This document has been carefully checked. However, Teseq® does not assume any liability for errors or inaccuracies. Specifications subject to change without notice.



Advanced Test Solutions for EMC