

# NSG 5500 AUTOMOTIVE TRANSIENT IMMUNITY TESTS



- Built-in 100 A coupler/battery switch
- Clean, compliant pulses on the single output
- All common international and vehicle manufacturer standard transients achieved in one compact solution
- Optional Dropout Switch
- Optional 8-channel Arbitrary waveform generator

The compact and modular NSG 5500 solution offers the generators necessary for tests with capacitive discharge pulsed interference as called for by ISO, SAE, DIN and JASO, and others. The established test specifications for passenger cars together with the new standards for commercial vehicles published by these international and other bodies are fully covered, as are the most company-specific standards from vehicle manufacturers. Based on our exclusive technology, Teseq offers the most flexible and upgradeable system to protect the users' investment.

NSG 5500 system. This compact mainframe houses the common system components and accommodates the standard pulse generators. All testing is available from one output connector. Overall control, reporting and an extensive standards library via a PC running AutoStar™ under Windows is available.

**NSG 5500 modules.** The NSG 5500 offers unprecedented flexibility for transient testing. Teseq has designed a solution with various transients in one modular and upgradeable chassis. The basic ISO 7637 tests for pulse 1, 2a, 3, 4, 5 (Load Dump) and variants, as well as classic pulses like 6 and 7 are integrated into the same chassis. A powerful arbitrary waveform generator for controlling a battery simulator for pulse 4 and pulse 2b, and much more, is available. When standards change, as they do every year, the NSG 5500 system may be upgraded with different modules, if necessary.

All NSG 5500 generators are calibrated in accordance with ISO 7637-2:2011 or manufacturer-specific standards. Teseq continues to maintain backwards compatibility and yet push the state of the art for EMC immunity testing.

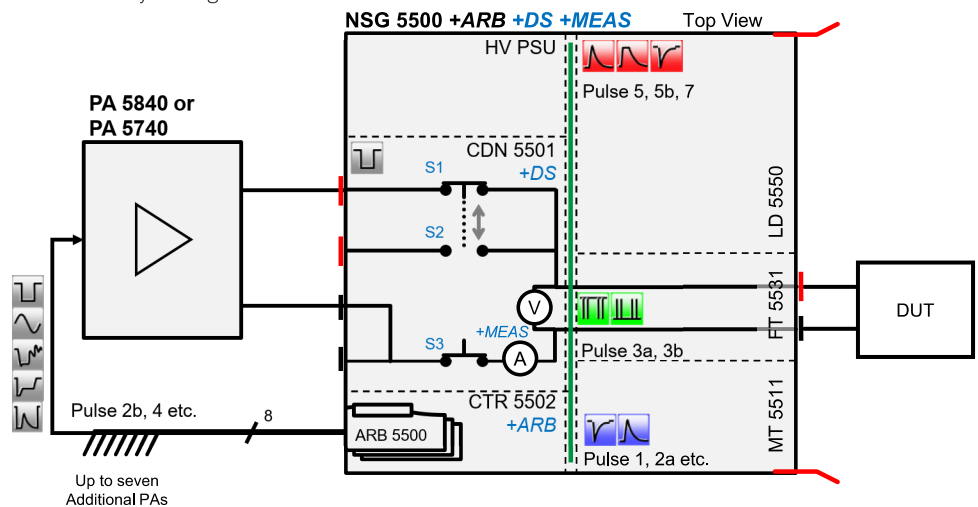

販売代理店

**国華電機株式会社**  
KOKKA ELECTRIC CO.,LTD.  
TEL : 06-6353-5551  
E-mail : webinfo@kokka-e.co.jp

For full details, see the complete catalog "Automotive Electrical Disturbances".

AMETEK CTS GmbH  
Sternenhofstrasse 15, 4153 Reinach, Switzerland  
T +41 32 681 40 40 F +41 32 681 40 48  
info.cts@ametec.com [www.teseq.com](http://www.teseq.com)  
691-177B February 2019

© February 2019 Teseq®  
Specifications subject to change without notice. AMETEK CTS is an ISO-registered company. Its products are designed and manufactured under the strict quality and environmental requirements of the ISO 9001. This document has been carefully checked. However, Teseq® does not assume any liability for errors or inaccuracies.

**T E S E Q**  
Advanced Test Solutions for EMC